

## Dräger Vyana Ceiling Supply Units

With a wide range of configurations and options to choose from, the Dräger Vyana ceiling supply unit is compact and highly ergonomic. It uses minimum care area space to support you with high quality patient care and is available in two variants: Rigid and Single arm.

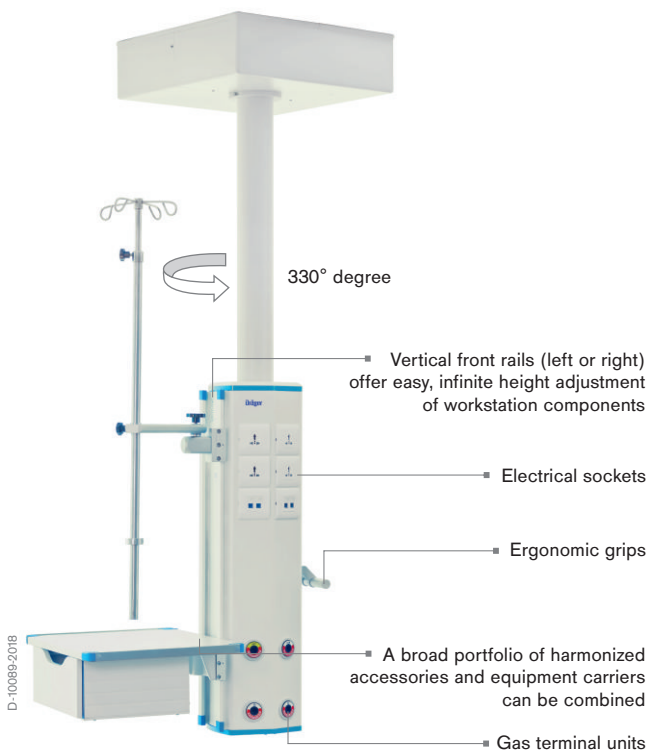

### Rigid



### Single Arm

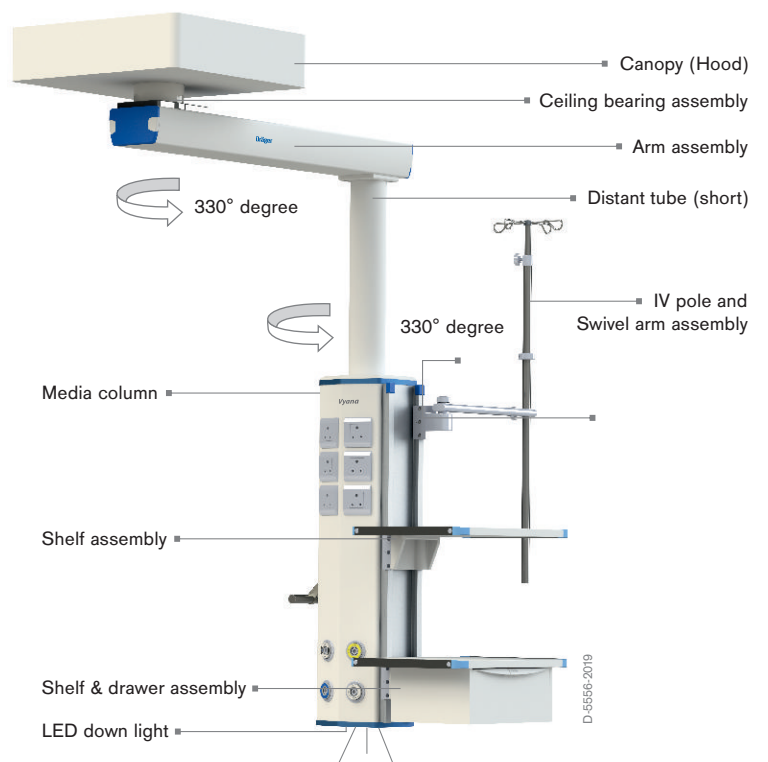



The Vyana standard column is available in lengths of 500 mm, 750 mm and 1000 mm. on a basic length of 1000 mm, it provides a fundamental configuration with 32 possible installation ports.



High quality terminal units from Dräger can be provided wherever they are required. Extensive installation opportunities make it possible to position the gas terminal units at the bottom guaranteeing an ergonomic arrangement of equipment and fulfilling smooth workflow requirements. The terminal units satisfy the DIN and British Quality criterions since the sockets are supplied in both standards.

Dräger's anesthetic gas scavenging system allows an essential reduction of gas concentration to protect the operating room team from anesthetic gases and minimizing the danger of explosion due to their mixture.

### Standard Color Offerings: RAL Shade Box and Code

Signal Yellow  
RAL 1003

Pastel Blue  
RAL 5024

White Aluminum  
RAL 9006

Traffic White  
RAL 9016



*Images are for illustration purposes only. Vyana can be customized in any RAL color upon request.*

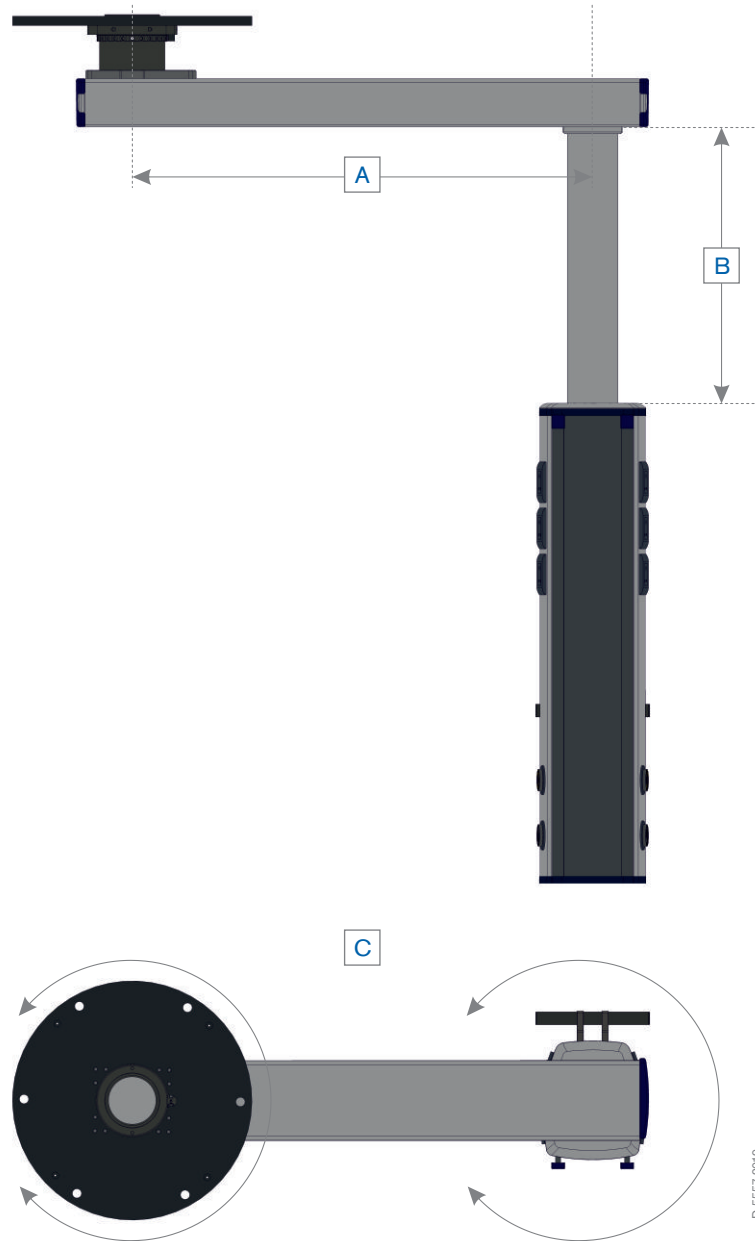

D-6657-2019

- A** Length of support arm for single arm ceiling supply unit
- B** Length of distant tube (short) for single arm system
- C** Swivel range 330°

## Benefits

---

### Fits more number of components

The Vyana can fit as many as 32 outlets on a 1 meter column (20 electrical outlets + 12 gas outlets or 16 electrical outlets + 16 gas outlets).

---

### Sleek design

Stylish and sleek design of the Vyana column makes it a preferred choice for premium Intensive Care Units and Operating Rooms.

---

### Customizability of the column

It is available in three lengths of 500 mm, 750 mm and 1000 mm. Vyana column features full-length media panels on both sides for the installation of terminals for gases and electricity or data as needed. The servicing and maintenance of Vyana becomes hassle free with its move away rear panel.

Vertical front rails with a total loading capacity of up to 80 kg offer easy and free height adjustment of shelves, drawers, extension arms and other workstation components.

---

### Vyana arm

Available in the length of 500, 750 and 1000mm. The smooth and corner less design of arm ensures easy cleaning and aids in infection prevention.

---

### Flexibility in positioning

The rotation feature of the Vyana column gives the user flexibility to position the medical devices up to 330° about the vertical axis. The rotation of arm upto 330° will give additional flexibility to position the column in the workplace. The one time adjustable friction breaks ensure the safe movement of devices about the vertical axis. Simple yet ergonomically designed handle allows users to quickly position the column.

---

### Robust and modular construction

Vyana is constructed from robust, extruded aluminum profiles. Rounded corners, edges and seamless fittings ensure safety, hygiene and easy cleaning.

## Accessories



D-10086-2018

### Shelf

The shelf consists of powder coated aluminum which provide smooth, scratch resistant and anti-static surface quality. The corner of the shelf features silicon attachment to protect against collision for safer use.



D-10086-2018

### Medical Rail

High quality medical rails compliant to the international medical standards are fitted on both sides of the shelf. It allows users to add more devices on to it. Each rail can carry a load of upto 5 kg. The load capacity of the shelf alone is upto 40 kg and together with medical rails it goes up to 50 kg.



D-10087-2018

### Drawer

Drawer can be optionally added below the shelf. The smooth slides of the drawer ensure noiseless operation.



D-10088-2018

### IV Pole

The height adjustable IV pole is suitable for attachments of up to 4 bottle holders. The stylish and ergonomic design provides a scratch free surface.



D-10089-2018

### Swivel Arm

The single arm version with one degree of rotation holds upto 15 kg of load. The 500 mm long swivel arm and adjustable pole allows user to position the bottle holder within a wide range of reach.



D-100100-2018

### Monitor Arm

The monitor arm can be able to hold upto 20 kg. of load. It has 3 degrees of freedom. The arm can be rotated about the vertical axis and the monitor holder can be rotated about the vertical axis as well as horizontal axis. This arm can be positioned along the length of the vertical rails provided on the Vyana column.

## Technical Data

### Vyana ceiling supply unit

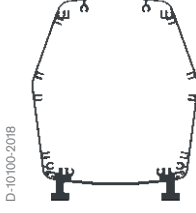
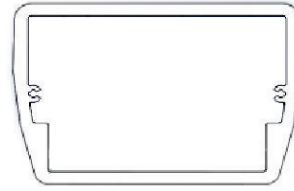
Column size	230 mm * 275 mm								
									
Arm size	175 mm * 105 mm								
									
Length of column	Any length from 500 mm to 1000 mm								
Length of arm	Any length from 500 mm to 1000 mm								
Outlets	Dräger DIN and BS gas terminal units for medical gases and vacuum, Indian Standard Institute (ISI) electrical sockets (max 16 A), data and telephone sockets or cut out for parts provided by customer, gas outlets, electrical sockets, nurse call etc.								
Outlet spacing	At least 200mm between gas terminal units (for flammable or oxidizing gases) and electrical outlets.								
Color options	4 standard RAL color shades to choose from - Signal Yellow - RAL 1003, White Aluminum - RAL 9006, Traffic White - RAL 9016, Pastel Blue - RAL 5024. Other RAL colors available on request								
LED light (Optional)	3 W LED down light for Floor illumination.								
Load capacity of single arm	<table border="1"> <thead> <tr> <th>Arm length</th> <th>Max load</th> </tr> </thead> <tbody> <tr> <td>500 mm</td> <td>80 Kg (total)</td> </tr> <tr> <td>750 mm</td> <td>80 Kg (total)</td> </tr> <tr> <td>1000mm</td> <td>80 Kg (total)</td> </tr> </tbody> </table>	Arm length	Max load	500 mm	80 Kg (total)	750 mm	80 Kg (total)	1000mm	80 Kg (total)
Arm length	Max load								
500 mm	80 Kg (total)								
750 mm	80 Kg (total)								
1000mm	80 Kg (total)								
Load capacity	Max. load of 80 kg (total)								
	<b>Accessories</b>								
Shelf load capacity	480 x 400 mm, fitted with medical rails on both side Individual shelf capacity of 40 kg, individual medical rail capacity of 5 kg								
Drawer load capacity	Outer dimension of 430 x 285 x 160 mm; fitted underneath the shelf Individual drawer capacity of 7 kg max.								
IV pole load capacity	Suitable for attachment of upto 4 infusion bottles; Length of pole of 1000 mm with variable height adjustment upto 800 mm. Max. load of 15 kg (total)								
Swivel arm load capacity	Length of swivel arm is 440 mm (center to center) with single degree of rotation Max. load of 15 Kg								
Monitor arm load capacity	Length of the monitor arm is 220 mm (center to center) having 3 degrees of rotation Max. load of 20 Kg								

## Notes

## Notes

Not all products, features, or services are for sale in all countries.  
Mentioned Trademarks are only registered in certain countries and not necessarily in the country in which this material is released. Go to [www.draeger.com/trademarks](http://www.draeger.com/trademarks) to find the current status.

Vyana Ceiling Supply Unit



Directive 93/42/EEC  
concerning Medical Devices

**Compliance to Following Standards**  
ISO 11197, IEC 60601-1

### EC REP

#### CORPORATE HEADQUARTERS

Drägerwerk AG & Co. KGaA  
Moislinger Allee 53-55,  
23542 Lübeck, Germany

[www.draeger.com](http://www.draeger.com)

#### MANUFACTURER

Dräger India Pvt. Ltd.  
10<sup>th</sup> Floor, Commerz II,  
International Business Park,  
Oberoi Garden City,  
Mohan Gokhale Road,  
Off Western Express Highway,  
Goregaon East, Mumbai - 400063

#### PRODUCTION FACILITY

Dräger India Pvt. Ltd.  
Bldg. Shed no. 4, 5 and 1,  
Deodal Village, Vasai Taluka,  
Dist. Palghar - 401208

#### MUMBAI (REGISTERED OFFICE)

Dräger India Pvt. Ltd.  
10<sup>th</sup> Floor, Commerz II,  
International Business Park,  
Oberoi Garden City,  
Mohan Gokhale Road,  
Off Western Express Highway,  
Goregaon East, Mumbai - 400063  
Tel +91 22 6133 5600  
[info.MT.india@draeger.com](mailto:info.MT.india@draeger.com)

#### BRANCH OFFICES

##### AHMEDABAD

2<sup>nd</sup> Floor, Panchamrut House,  
Near Panchamrut - 2, Bungalows,  
Near. Science City Bridge, Sola,  
Ahmedabad - 380060  
Tel +91 79 2929 9101  
Fax +91 79 2929 9101

##### BENGALURU

2<sup>nd</sup> Floor, No. 179, Amarjyoti Layout,  
Intermediate Ring Road,  
Domlur, Bengaluru - 560071  
Tel +91 80 4167 2869/70  
Fax +91 80 4098 5455

##### HENNAI

C/o FedEx Express TSCS (I) Pvt. Ltd.  
77/1, 2A, 2B, Redhills Road,  
Opp. Pappad Company, Kathirvedu,  
Chennai - 600066  
Tel +91 44 4351 9701/02  
Fax +91 44 4351 9703

##### KOCHI

Ground Floor, Soorya Prabha Bldg.,  
Door No. 35/230D,  
(40/287-A), Prabha Lane,  
Automobile Road, Lane 8,  
Mamangalam, Palarivattom,  
Kochi - 682025  
Tel +91 484 4013 118  
Fax +91 484 3016 063

##### KOLKATA

1<sup>st</sup> Floor, Sanjoy Bhavan,  
44th Shanti Pally,  
Kolkata - 700107  
Tel +91 33 4063 0375/76  
Fax +91 33 4063 0377

##### LUCKNOW

7<sup>th</sup> Floor, BBD Viraj Towers,  
TCG/1 AV/3, Vibhuti Khand,  
Gomti Nagar, Lucknow,  
Uttar Pradesh - 226610  
Tel +91 522 410 6890

##### NEW DELHI

B2-3, Ground Floor,  
Africa Avenue Road,  
Safdarjung Enclave,  
New Delhi - 110029  
Tel +91 11 4604 8436/40  
Fax +91 11 4615 1401

Locate your Regional Sales  
Representative at:  
[www.draeger.com/contact](http://www.draeger.com/contact)

